

# **EDGEWATER DESIGN STANDARDS**

CITY OF EDGEWATER 2401 SHERIDAN BOULEVARD EDGEWATER COLORADO 80214



**DAVID LYNN WISE AIA**  
Architecture + Urban Design

SERIES A, B, AND C

NOVEMBER 25, 2003

# EDGEWATER DESIGN STANDARDS

City of Edgewater 2401 Sheridan Boulevard Edgewater Colorado 80214

## TABLE OF CONTENTS

**OVERVIEW** - Aerial Photograph with C-1 Zone Project Area

### **25<sup>TH</sup> AVENUE**

- A.1 Height and Massing
- A.2 Setbacks and Build-To Lines
- A.3 Storefront Design
- A.4 Sign Design
- A.5 Exterior Building Materials
- A.6 Intermediate and Top Floor Design
- A.7 Multi-Family Residential Window and Balcony Orientation
- A.8 Roof Decks
- A.9 Outdoor Dining - Canopies, Railings, Lighting
- A.10 Parking - Concept for Increased Parking Capacity
- A.11 West End, Middle, East End Guidelines

### **SHERIDAN BOULEVARD**

- B.1 Height and Massing
- B.2 Setbacks and Build-To Lines
- B.3 Curb Cut Elimination
- B.4 Streetscaping Guidelines
- B.5 Ground Floor Retail Glazing, Windows and Doors
- B.6 Upper Floor Glazing, Windows and Doors
- B.7 Roof Deck, Pergola, Canopy and Railing Design
- B.8 Exterior Building Materials
- B.9 Architectural Design Guidelines
- B.10 Sign Design
- B.11 Commercial Zone Parking Pressure on Adjacent Residential Districts
- B.12 Enhance Existing Small Businesses
- B.13 Trash Enclosures
- B.14 Balconies
- B.15 Height and Massing Alternatives
- B.16 Corner Glazing
- B.17 Arcades

### **20<sup>TH</sup> AVENUE**

- C.1 Height and Massing
- C.2 Setbacks and Build-To Lines
- C.3 Storefront Design
- C.4.a Storefront Sign Design
- C.4.b Ground Sign Design
- C.5 Materials Guidelines
- C.6 Intermediate and Top Floor Design Guidelines
- C.7 West End, Middle Section, East End Guidelines
- C.8 Streetscaping Design
- C.9 Architectural Design

**REFERENCE** - Architectural Example Files, Sign Example Files

**DAVID LYNN WISE AIA**

Architecture + Urban Design

1104 EAST 17TH AVE DENVER CO 80218

303 . 446 . 5965 FAX 303 . 830 . 1124

email david @ davidlynnwise.com



**CITY OF EDGEWATER URBAN DESIGN STANDARDS**



1 of 2

Note: This document is for reference in establishing design standards and is not an official policy document of the City of Edgewater

## A.1 HEIGHT AND MASSING

### ISSUE

The current scale of 25th Avenue combined with the relatively shallow lots indicate that a building height of 100' is taller than would be compatible with the existing context and uses. A height limit that is too great will create pressure to assemble property zoned residential in order to yield lots large enough to accommodate tall buildings.

### DESIGN STANDARD

- Provide structures limited in height to 45' to top of roof structure and three stories maximum.
- Minimize the pressure to develop taller buildings in the 25th avenue district.
- Maintain a district of pedestrian scale buildings.
- Encourage mixed use buildings including retail, office and residential on separate floors of three story buildings. Provide services and parking behind and below grade under such buildings.

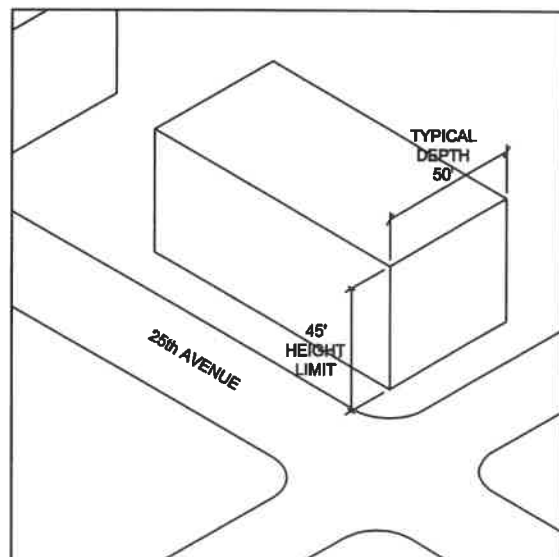
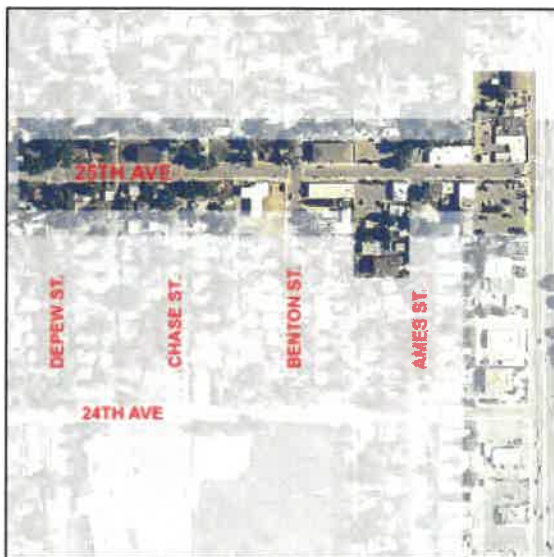

## A.2 SETBACKS AND BUILD-TO LINES

### ISSUE

Commercial structures at the east and west ends of 25th Avenue between Sheridan and Gray typically are located tight to the 25th Avenue property line. Due to the shallow depth of the lots currently zoned C-1 any front setback appears to be impractical. The commercial structures set tight to the property line create a continuous streetscape to pedestrians and make good use of the commercial property.

### DESIGN STANDARD

- Maintain the 25th Avenue property line as a build to line.
- Establish build-to lines at 25th Avenue property lines in blocks characterized by commercial storefronts.
- Limit breaks in the continuity of the building frontage to 20% of the property line dimension facing 25th Avenue.

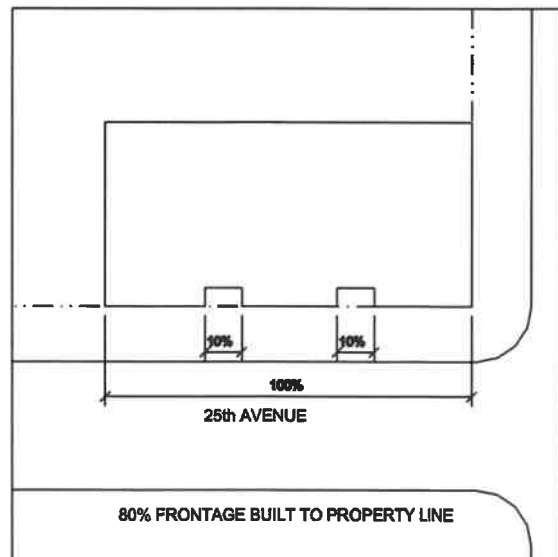
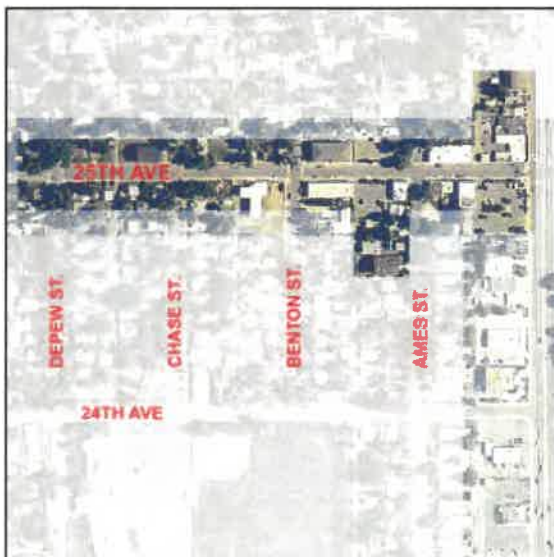

SETBACK EXAMPLE

Sheet Number



### A.3 STOREFRONT DESIGN

#### ISSUE

Continuous glass building fronts with doors fronting the street create a unified and inviting appearance for commercial storefronts.

#### DESIGN STANDARD

- Provide 70% transparent glass storefronts at the ground floor elevation of all commercial buildings facing 25th Avenue. Additionally, corner lots should also provide 70% glass storefronts at side elevations.
- Provide doors at commercial spaces with 50% glass fronting the street and recessed to allow door to swing out.
- Provide storefronts designed to follow traditional details and proportions as established by the U.S. Department of Interior.

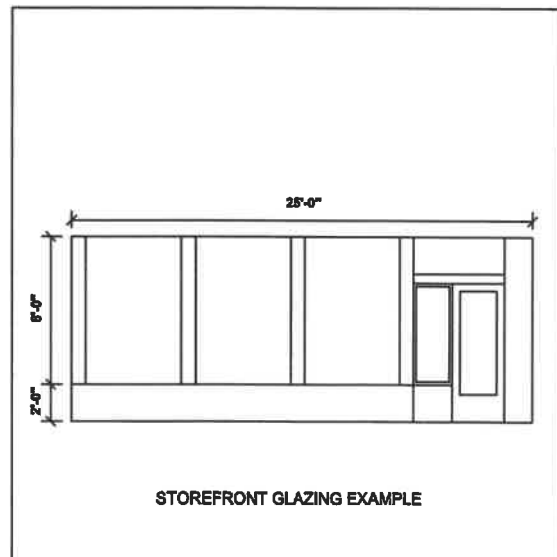
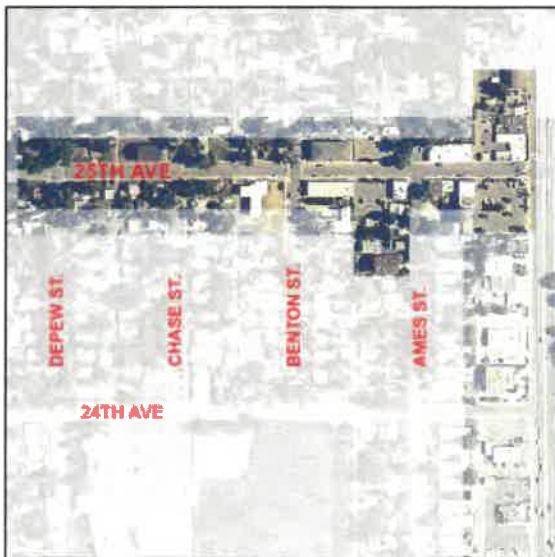

## A.4 STOREFRONT SIGN GUIDELINES

### ISSUE

Signs oriented toward pedestrians and visible as one walks along the street typically are projecting signs. The most effective signs incorporate interesting sculptural elements which communicate the type of shop without relying only on words. Projecting signs on the storefronts of the East end of 25th Avenue will be more visible from Sheridan Boulevard than wall signs.

### DESIGN STANDARD

- Provide storefront signs that are projecting signs designed to fit within a 4 foot cube and that incorporate a sculptural element indicating the type of shop or business and with relatively small type used for words.
- Encourage high quality materials, design and craftsmanship in the production of signs.
- Discourage the use of plastics and other low quality materials in the fabrication of signs.
- Limit the amount of glare and spilled light from signs and canopies.
- Encourage careful, high quality lighting of signs.

The use of fluorescent lighting in new signs and canopies is not allowed.

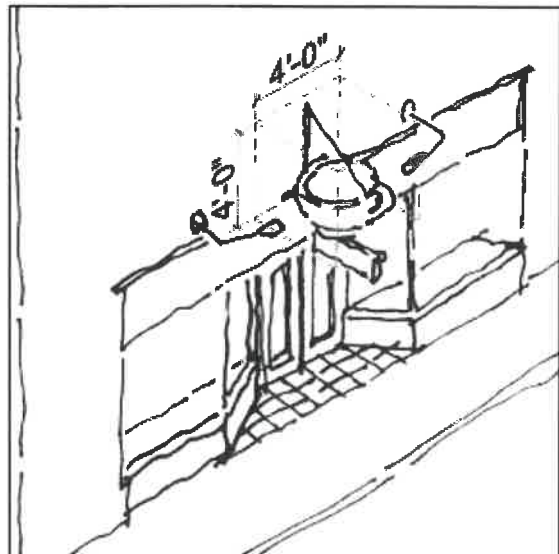
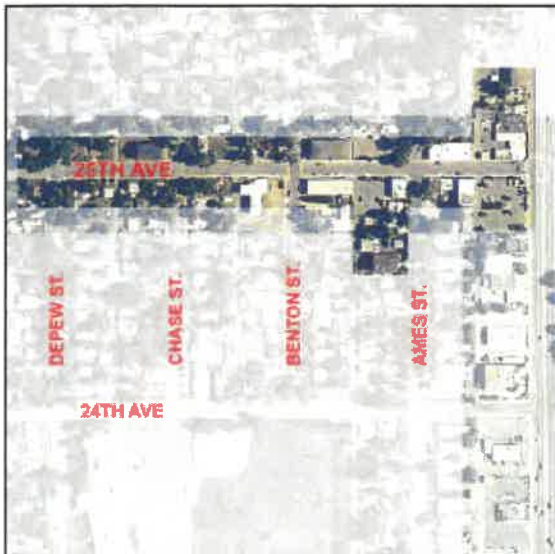

## A.5 EXTERIOR BUILDING MATERIALS

### ISSUE

Most commercial structures on 25th Avenue are constructed with brick on the building fronts. This is one of the most consistent and memorable architectural traits of the commercial buildings on the east and west ends of 25th Avenue. The existing brick structures convey a sense of high quality construction and traditional character and this should be reinforced with the construction of each new building.

### DESIGN STANDARD

- Provide high quality brick masonry construction for all exterior wall surfaces at all new commercial building fronts on 25th Avenue and at all walls facing side streets at corners. Back walls and alley walls may be stucco.
- Brick materials are to be similar to the existing buildings in size, module and in surface texture.
- Downgraded materials such as synthetic stucco, wood siding, metal siding, vinyl siding, cement siding, concrete masonry and other substitutions are not allowed.

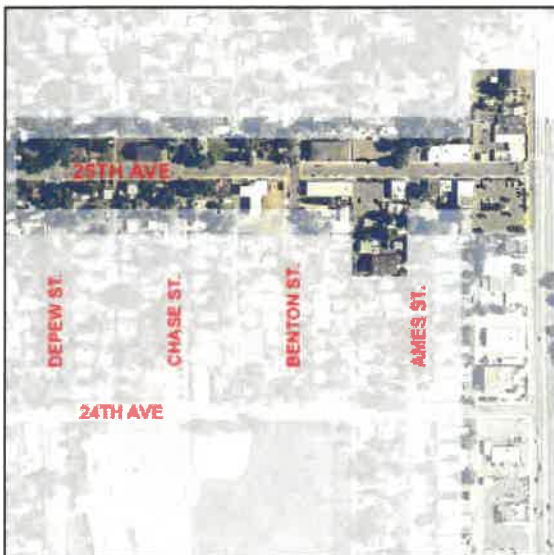



## A.6 INTERMEDIATE AND TOP FLOOR DESIGN

### ISSUE

Intermediate and top floors can be designed to unify the character of a particular block and to allow the interior to relate to and reinforce the sense of lively activity on the street.

### DESIGN STANDARD

- Provide large operable windows designed to face the street on all upper levels.
- Encourage the design of projecting bay rooms, bay windows, planter boxes and balconies facing the street.
- Encourage the design of balcony railings that conceal clutter stored on balconies.
- Encourage the design of buildings to take advantage of views from upper floors by incorporating balconies and roof decks.
- Provide decks and balconies designed to be visible from the street.



## A.7 MULTIFAMILY RESIDENTIAL WINDOW AND BALCONY ORIENTATION

### ISSUE

Multi-Family residential units facing the street can be designed to enhance the streetscape and to visually connect to the activity of the street. Residential units can make the street safer by providing full time users and around the clock eyes to supervise the activity of the street.

### DESIGN STANDARD

- Encourage multi-family residential building design that orients the main living spaces facing the street and overlooking the street through large windows as well as from balconies.
- Encourage a large proportion of the balconies to overlook the street and provide a visual connection to the activity of the street.

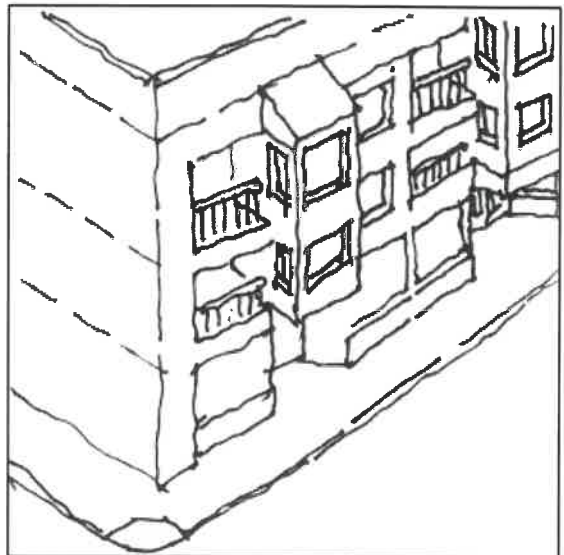
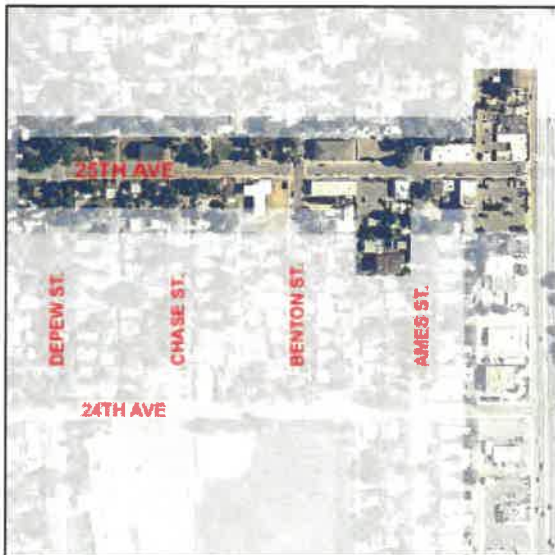

## A.8 ROOF DECKS

### ISSUE

The location of Edgewater provides attractive views of Sloans Lake as well as the Rocky Mountains from the vantage point of the many of the roofs of 25th Avenue. These views are non-existent from the street level and are not currently part of the attraction of visiting 25th Avenue businesses.

### DESIGN STANDARD

- Encourage development of roof decks on new and existing buildings on 25th Avenue.
- Require that the new roof decks have canopies or shade trellises and that they are visible and attractive from the street.
- Roof deck awnings are not allowed to protrude above the 45 foot height limit.
- Provide code compliance guidance to ensure convenience and safety in reaching the decks using stairs and elevators.
- Set stairs within the envelope of the building.
- Orient stairs and elevators to the street to make them inviting and easy to find and use.

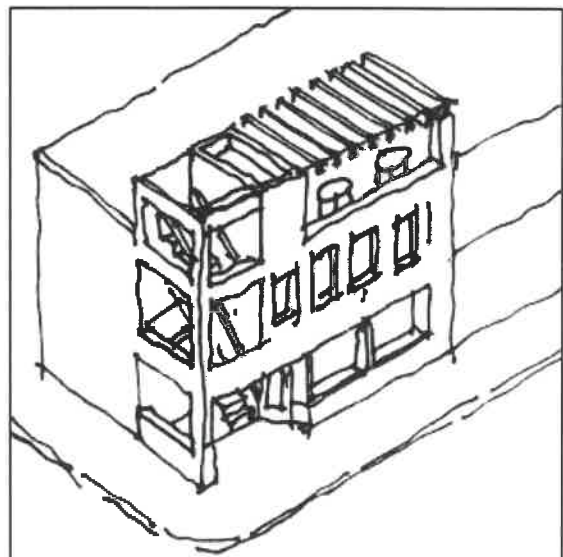
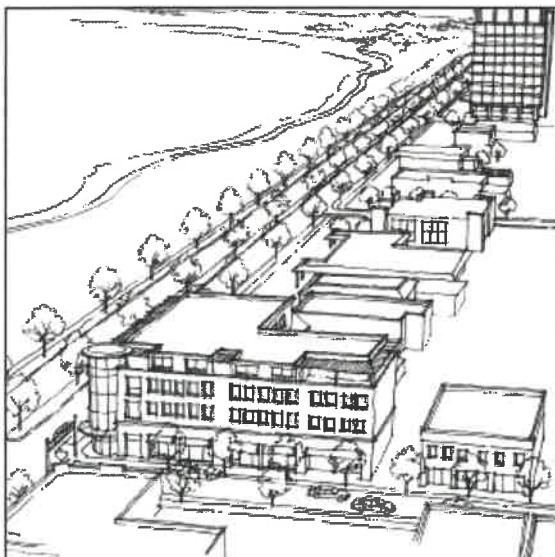



## A.9 OUTDOOR DINING - CANOPIES, RAILINGS, LIGHTING

### ISSUE

Dining and drinking establishments are an important component of the character and business activity of 25th Avenue. Visible street activity and inviting street scenes are important to attracting more visitors to the commercial areas of 25th Avenue. Space is limited for outdoor dining with the current sidewalk width.

### DESIGN STANDARD

- Encourage design of outdoor dining and seating on 25th Avenue.
- Encourage business district support for wider sidewalks and street trees on the south side of 25th Avenue.
- Encourage well designed painted steel or aluminum railings to enclose outdoor seating.
- Provide canopies and awnings with high quality, sunlight resistant fabric that is well supported to maintain the canopy shape.
- Provide outdoor lighting for seating areas which is attractive, emits low glare and which is appropriate for dining.

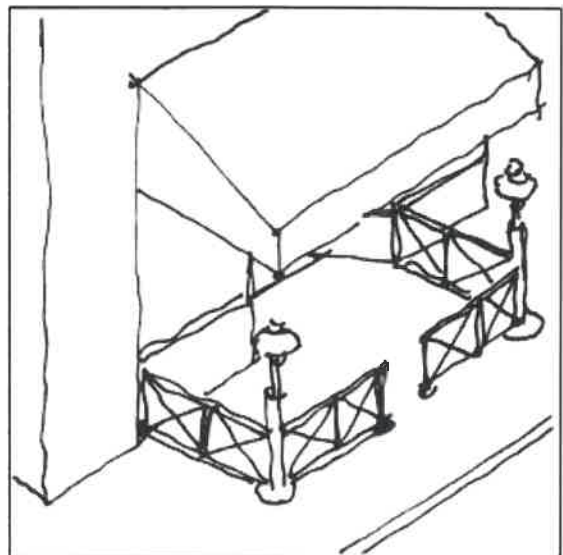

## A.10 PARKING- CONCEPT FOR INCREASED PARKING CAPACITY

### ISSUE

Increased commercial and residential development on 25th Avenue will increase the demand for parking. Relatively shallow depths of C-1 zone lots combined with the possible elimination of on street parking on the south side of the east end of 25th Avenue makes accommodating additional parking difficult.

### DESIGN STANDARD

- At all new buildings on 25th Avenue provide parking either on the side of the property away from 25th Avenue or below grade - under the building.
- On 25th Avenue on-street parking may be counted toward the parking requirement for any project, provided on-street parking is immediately in front of or adjacent to the building.
- Claiming adjacent residential property for parking is disallowed.
- Business district support should be given to increasing the parking capacity of the commercial district on 25th Avenue. This may involve developing the municipal property at 25th and Sheridan or another site as a mixed use parking structure with ground floor commercial frontage. This is a planning concept only and is not a funded or City endorsed project.

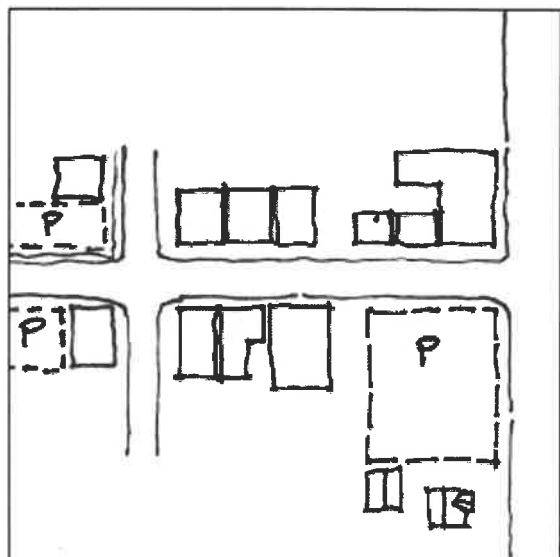
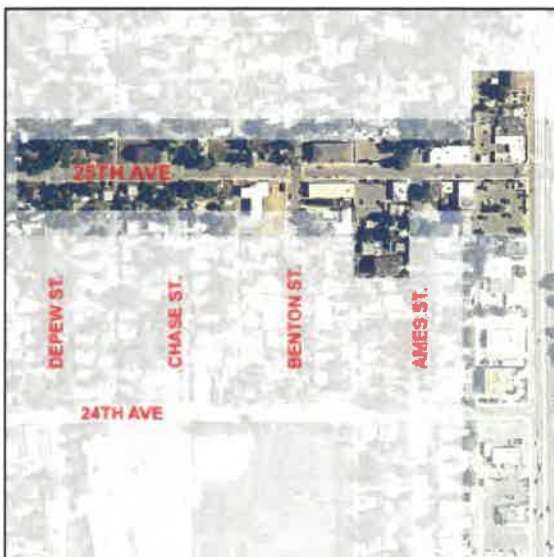

## A.11 WEST END, MIDDLE, EAST END GUIDELINES

### ISSUE

The entire length of 25th Avenue from Sheridan to Gray is covered by the same C-1 zoning and for the most part the size and configuration of lots is the same. In its current form the segments of 25th Avenue are not alike and various areas of distinct character including commercial uses, residential uses and larger institutional uses occur along the length of the avenue

### DESIGN STANDARD

- Care should be taken in implementing the guidelines in reviewing current zoning as it relates to the existing character of 25th Avenue.
- Residential areas deserving of preservation should be given special attention.
- Guidelines created to assist the development and health of commercial uses should not be applied to the residential areas and other provisions should be made.
- The west end commercial area guidelines should be revisited as needed as new uses are developed which distinguish that area from the east end of 25th Avenue.

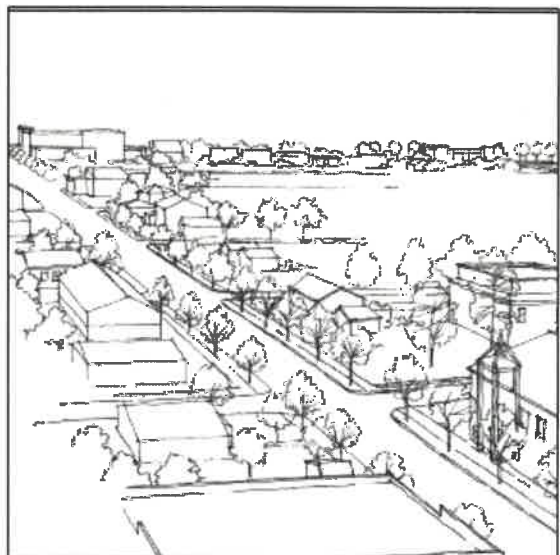
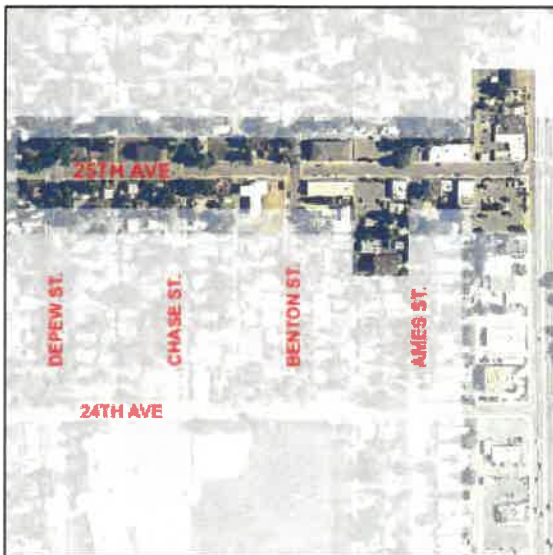



## B.1 HEIGHT AND MASSING

### ISSUE

The blocks fronting Sheridan Boulevard zoned C-1 previously had a 100' height limit and a 30' minimum front setback requirement. These dimensions potentially encourage a wall like development up to ten stories tall. This form would have blocked views to the mountains and to the lake from other Edgewater properties. The density previously allowed by zoning had the potential to create great pressure to rezone and redevelop the single family neighborhoods immediately to the west adjacent to C-1.

### DESIGN STANDARD

- The massing and form of development along Sheridan Boulevard should be guided to preserve views through the blocks without reducing the appropriate density of new structures.
- Massing is encouraged to create more elegant landmark buildings addressing the views to the east of the lake with the downtown skyline beyond and to the west to the mountains.
- Require massing so that two thirds of the frontage of any proposed development parcel must be no more than three stories or 45 feet tall while incorporating massing no more than six stories or 75 feet tall on the remaining one third of the parcel frontage.
- Limit the width of the taller massing on the east and west elevations to a dimension of 60 feet.
- The design of monolithic buildings is not allowed.

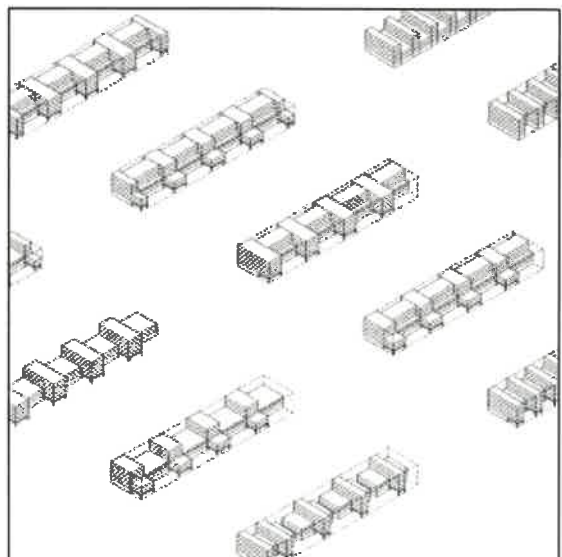
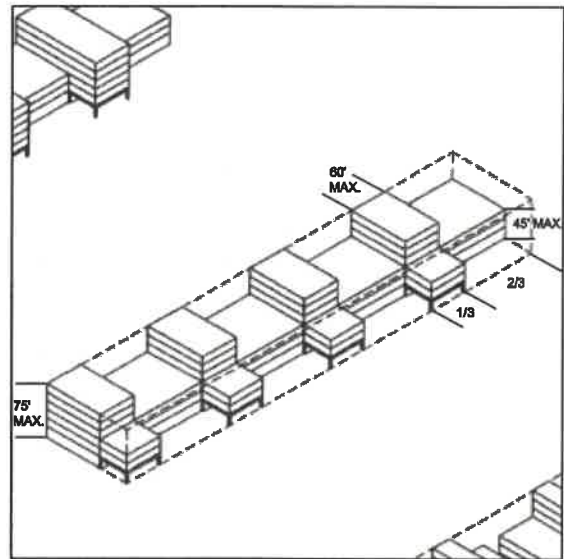

## B.2 SETBACKS AND BUILD TO LINES

### ISSUE

The blocks fronting Sheridan Boulevard zoned C-1 previously had a minimum 30' front setback. A 30' space is too narrow for parking while using up a significant percentage of available lot size. Limited space for parking may put pressure on adjacent residential zones for parking to serve the C-1 zone.

### DESIGN STANDARD

- Proposed developments must be built to a line inset 42 feet from the Sheridan Boulevard property line or to a build-to line tight to the property line.
- Proposed developments must set the building entry canopy and commercial storefronts close to the Sheridan Boulevard sidewalk. No other setbacks are allowed for the first three stories.
- Establish the location of new structures at Sheridan Boulevard to create a unified and consistent frontage addressing the Boulevard and the lake.
- Encourage the design of enhanced landscaping to relate to the proposed landscaping of Sheridan Boulevard and Sloan's Lake Park.

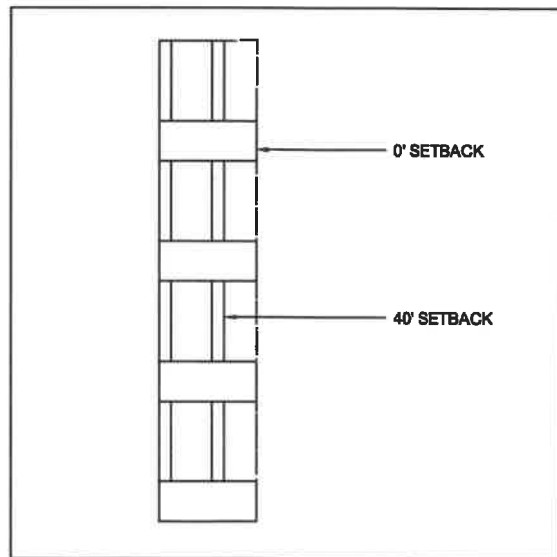
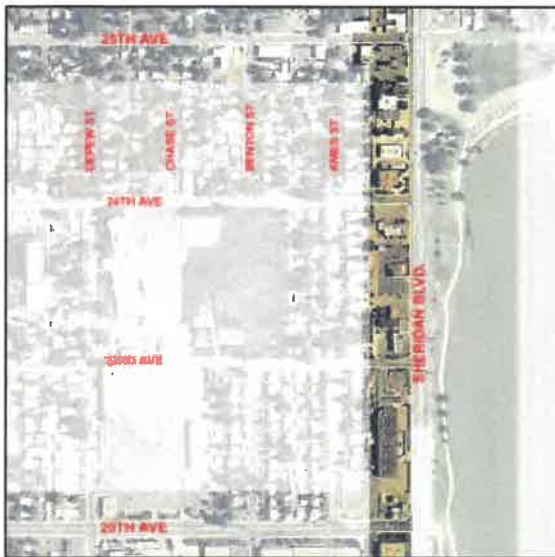

## B.3 CURB CUT ELIMINATION

### ISSUE

Multiple curb cuts along Sheridan Boulevard serving auto oriented businesses on small lots have made the construction of the deceleration lane important for convenience and safety entering and exiting those locations. The added lane has severely restricted the space available for pedestrians, buffering and landscaping along the west side of Sheridan Boulevard.

### DESIGN STANDARD

- Provide for the long term redevelopment of the C-1 high density commercial district along Sheridan Boulevard by restricting curb cuts on Sheridan as larger lots are redeveloped.
- Limit auto access to new developments to side streets or to right in, right out points on Sheridan Boulevard.
- Adapt all new plans to redevelopment of the deceleration lane as tree lawn and sidewalk space appropriate to larger high quality high density development.
- Incorporate in all new plans a pedestrian environment on Sheridan which is wider and less affected by the auto traffic similar in proportion and landscape quality to the Marketplace frontage.

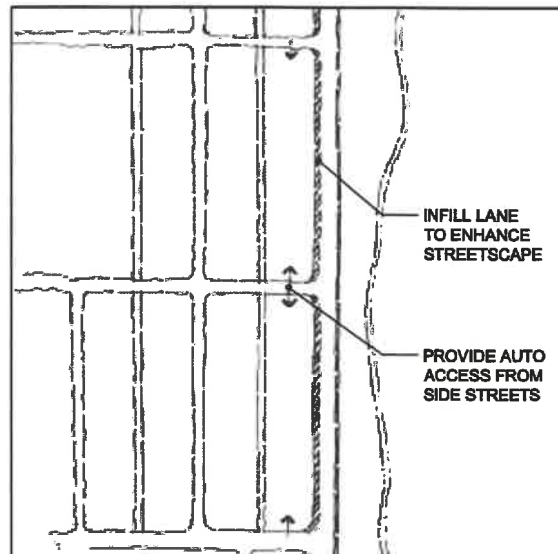
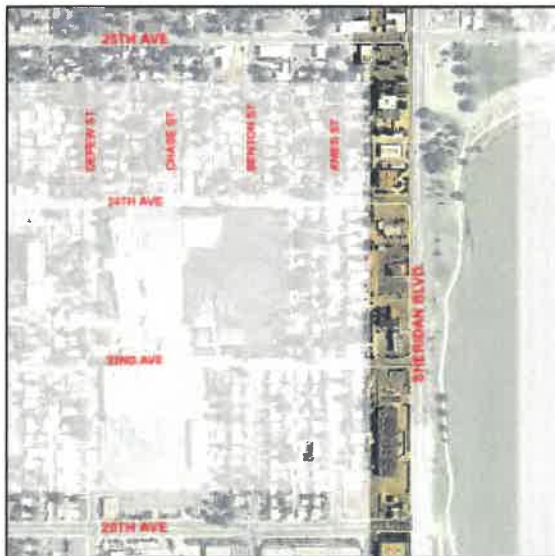



## B.4 STREETSCAPING GUIDELINES

### ISSUE

The current landscape guidelines on Sheridan Boulevard have made a significant improvement to the pedestrian environment and appearance of certain properties. Those improvements should be elaborated on and incorporated into a more appropriate design as additional properties and larger parcels are redeveloped. The streetscape should be designed in conjunction with any plans for a new pedestrian crossing to the park to discourage jaywalking and improve the safety of Sheridan Boulevard.

### DESIGN STANDARD

- Provide ongoing improvement of the frontage and streetscape along Sheridan Boulevard.
- With each development application for parcels fronting Sheridan Boulevard, examine and evaluate the possibility of reclaiming the deceleration lane as space for streetscaping.
- Incorporate street trees, tree lawns and detached sidewalks into the space which may be reclaimed from the elimination of the deceleration lane.
- Design the tree lawn and planting to discourage jaywalking.
- Preserve and enhance the pedestrian lighting currently in use.

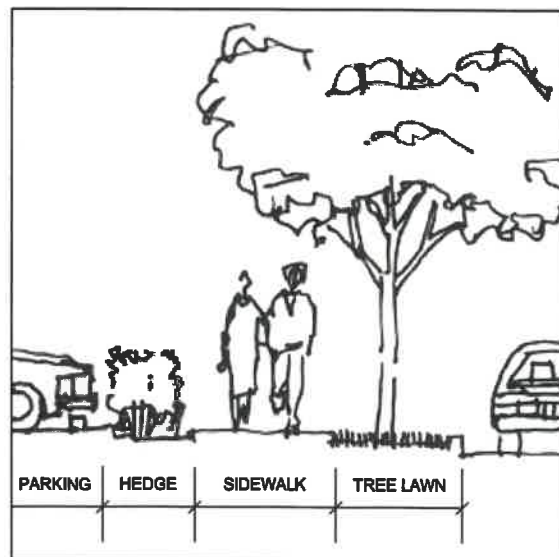

## B.5 GROUND FLOOR RETAIL GLAZING, WINDOWS AND DOORS

### ISSUE

The pedestrian environment of Sheridan Boulevard is chaotic and fragmented as currently developed. Buildings along Sheridan do not currently relate to the street in a consistent or inviting way. Some businesses relate nicely with large windows, well defined entry doors and landscaping. Others lack all of these things presenting a forbidding appearance to the street while discouraging new commercial activity.

### DESIGN STANDARD

- Incorporate 70% transparent glass in all ground floor commercial spaces and residential lobbies.
- Encourage arcades, colonnades and canopies as elements attractive and welcoming to pedestrians.
- Orient building entries toward Sheridan Boulevard and make them clearly visible to passersby.

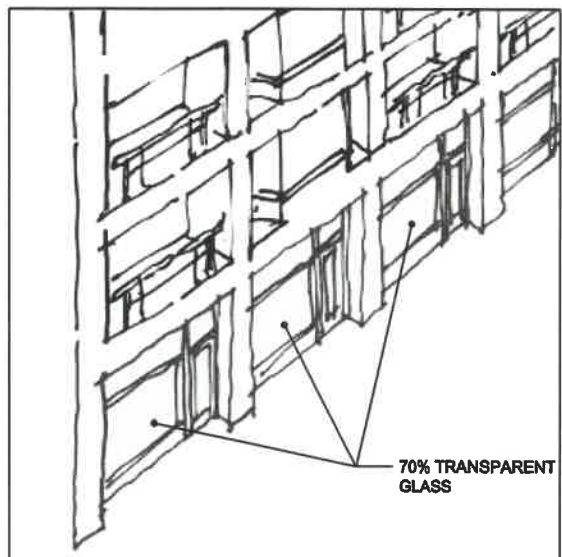

## B.6 UPPER FLOOR GLAZING, WINDOWS AND DOORS

### ISSUE

Residential units facing Sheridan Boulevard have the potential to enhance the streetscape and to visually connect to the activity of the boulevard and park to the east as well as to the neighborhood to the west.

### DESIGN STANDARD

- Encourage design of buildings that orient the main living spaces toward Sheridan Boulevard and take advantage of the views through large clear glass windows, glass doors and from balconies.
- Provide a visual connection to the activity of the sidewalk and park by requiring that a large proportion of the balconies overlook the boulevard.
- Residential units looking toward the lake and the mountains should be designed to take full advantage of those views.

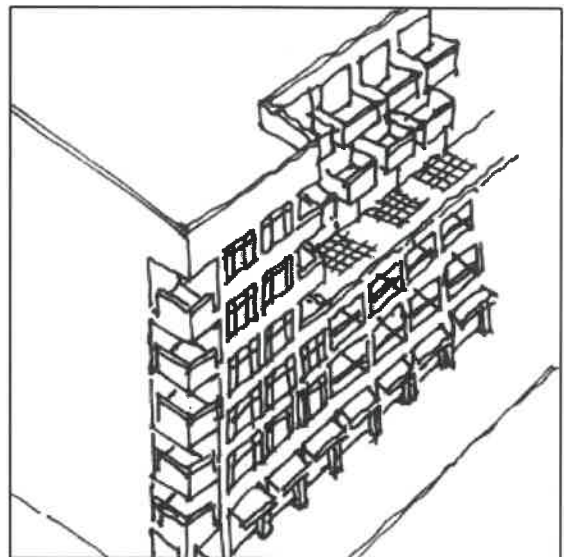



## B.7 ROOF DECK, PERGOLA, CANOPY, AND RAILING DESIGN

### ISSUE

Upper floors of buildings lining Sheridan Boulevard have some of the best views in the Metro Area. Roof decks will benefit from those views, and the architecture of these buildings should celebrate their roof deck amenities by making them visible from the boulevard and the park.

### DESIGN STANDARD

- Encourage roof decks on new residential and commercial developments.
- Provide canopies or pergolas covering the decks to make them visible from the boulevard and the park.
- Awnings and canopies are not allowed to protrude above the 75 foot height limit.
- Provide railing design to conceal any clutter on the decks.
- Encourage roof deck planting to relate to the proposed planting of the Sheridan Boulevard and the planting of Sloan's Lake Park.

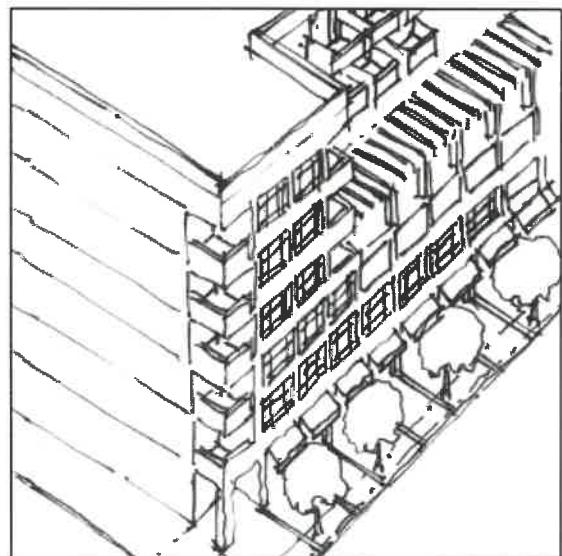

## B.8 EXTERIOR BUILDING MATERIALS

### ISSUE

Developers are often under pressure to use cheap, poor quality and bland materials in the development of new structures. At the same time, some degree of consistency in the use and quality of materials gives a district a clear identity and helps preserve the value of neighboring properties. It is possible to establish a community standard for the use of materials and doing it in advance of development pressure helps level the playing field for developers and ensure a consistent level of construction quality.

### DESIGN STANDARD

- The use of downgraded materials such as all synthetic stucco products, concrete masonry, wood siding, vinyl siding and vinyl windows is not allowed.
- The use of metal clad windows, metal glazing frames, non-reflective glazing, lightly tinted glazing, stone masonry, brick masonry, ceramic tile, and certain types of architectural grade cast concrete is required.
- Full scale wall assembly mockups are required for approval.
- Signs are not allowed on the west side of any structure.

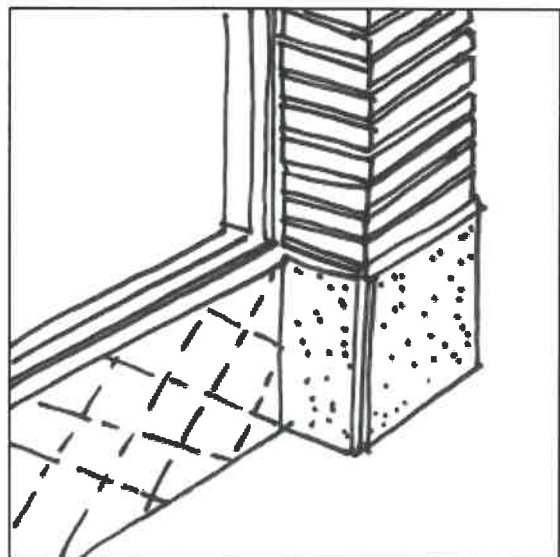

## B.9 ARCHITECTURAL DESIGN GUIDELINES

### ISSUE

The community of Edgewater has chosen to establish the architectural character of new development along the Sheridan Boulevard corridor. A consistent, appropriate architectural expression will help create a positive new identity for the redevelopment of Sheridan Boulevard.

### DESIGN STANDARD

Sheridan Boulevard between 20th and 25th Avenue is a waterfront site. Designs should refer to attractive precedents for multi-story buildings situated on waterfronts in sunny climates.

- Provide designs incorporating clean horizontal and vertical lines, bright surfaces, white or light neutral colors, crisp, minimal details and a predominance of large openings, roof decks and balconies.
- Provide landscaping that includes ornamental trees, water features, and low walls defining terraces which relate to the building and give unity to the project.
- Provide transitions to the street that include entry canopies as well as high quality signs. Provide exterior lighting for a dramatic visual image which reflects off the water at night.

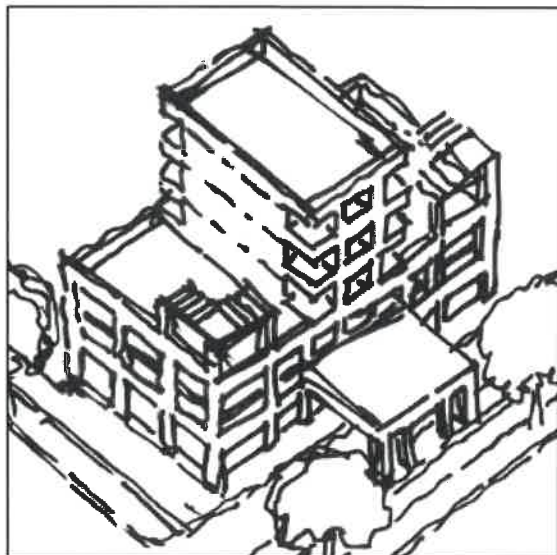
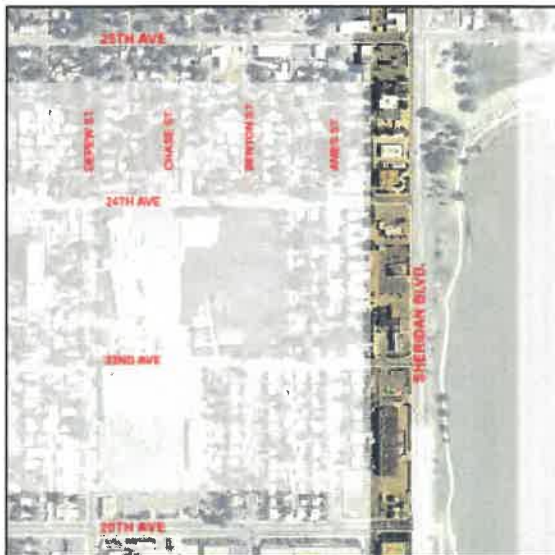



## B.10 SIGN DESIGN

### ISSUE

High quality signs, presented consistently from one property to the next can enhance the overall character of Sheridan Boulevard as properties are redeveloped. At the same time, poor quality, inconsistent signs can detract from the overall image of Sheridan Boulevard and negate other public improvements and investments in the area.

### DESIGN STANDARD

- Guide the design of signs to be prominent but low in height similar to the Marketplace.
- Discourage the use of visibly thin plastic elements, large plastic surfaces and internally lighted box signs.
- Incorporate high quality materials including metal, stone, glass and neon. Provide low glare lighting for signs.
- All provisions of the Marketplace sign requirements are incorporated into these standards.
- More stringent requirements of these standards take precedence over the Marketplace requirements.

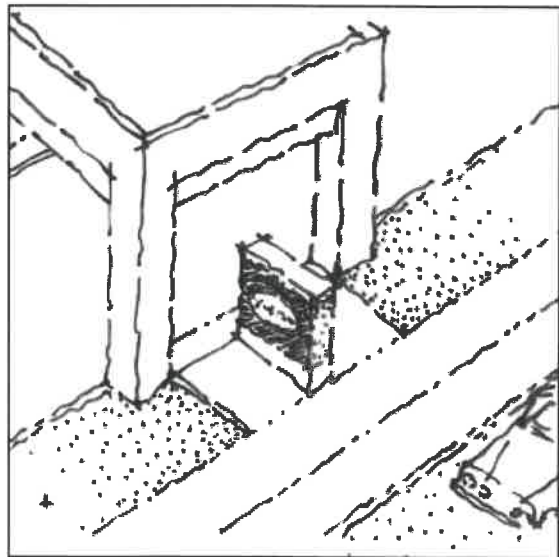
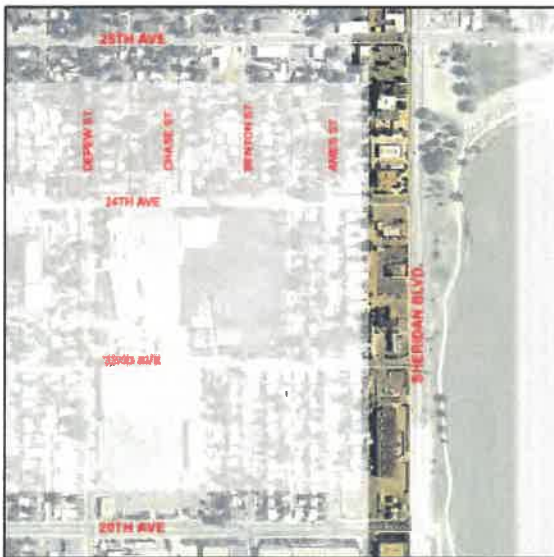
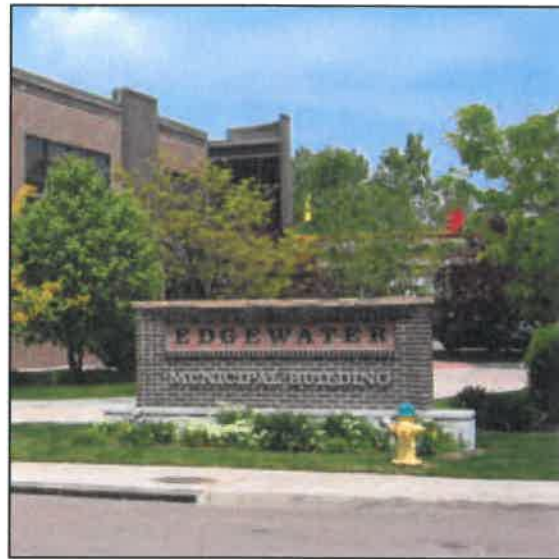

## B.11 COMMERCIAL ZONE PARKING PRESSURE ON ADJACENT DISTRICTS

### ISSUE

Parking facilities serving the C-1 district have begun encroaching into the residential districts.

### DESIGN STANDARD

Mitigate the influence of commercial parking in residential areas by encouraging the following:

- Landscape and screen parking lots to prevent traffic and glare from affecting the residents nearby.
- Integrate uses in the parking facility, such as housing, which are compatible with the adjacent residential areas in a manner which screens the parking.
- Provide active uses looking directly onto the parking facility to discourage crime and disruptive behavior in the parking facility.
- Provide low glare security and decorative lighting.
- Plan for other active uses, such as retail, to give life to and discourage crime in the parking facility.

Note: On-street parking cannot be counted toward the parking requirement for any project.

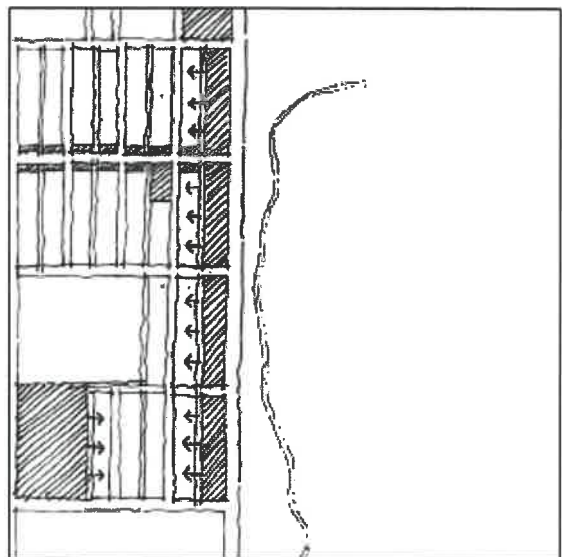

## B.12 ENHANCE EXISTING SMALL BUSINESSES

### ISSUE

The existing small businesses along Sheridan Boulevard represent a healthy and diverse district which may benefit from guidance for site improvements.

### DESIGN STANDARD

Enhance the Sheridan Boulevard pedestrian environment and the character of the district by encouraging the following:

- Trees planted near the sidewalk at the edge of parking lots to compliment the hedges.
- Improved sign design, sign material quality and sign lighting per B.10.
- Concrete, brick or unit paver paved pedestrian connections from the sidewalk, across asphalt parking and driveways to business entries.

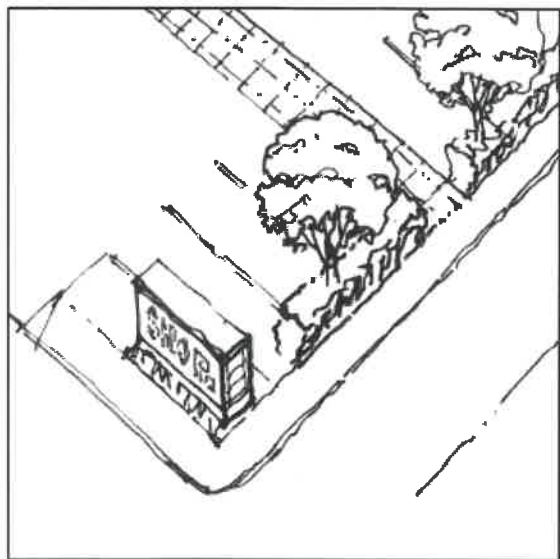
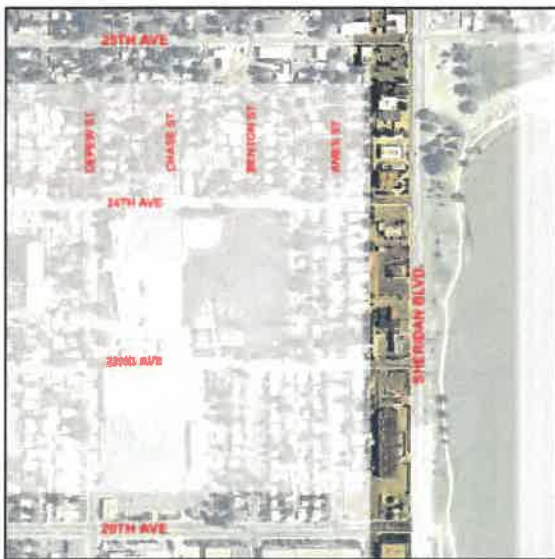



## B.13 TRASH ENCLOSURES

### ISSUE

The existing C-1 zoning borders residential areas. Trash facilities serving commercial buildings can create a nuisance for residential neighbors.

### DESIGN STANDARD

- Provide enclosures within new development projects for all trash dumpsters and other waste containers.
- Provide locking doors at all such enclosures.
- Dumpsters must be fully screened from view by adjacent residential neighbors.



INADEQUATE SCREENING

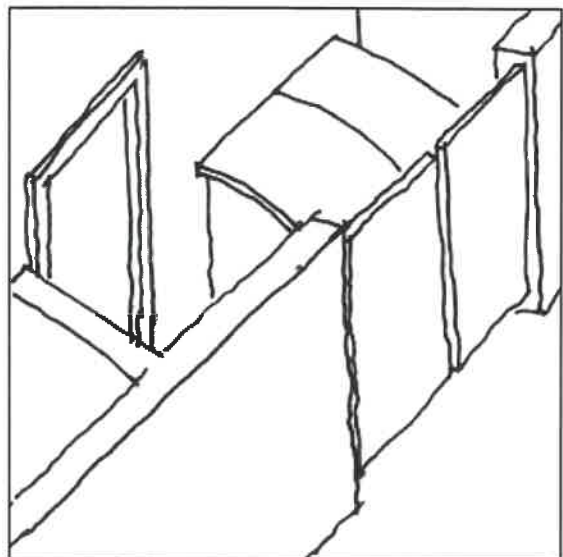

TRASH ENCLOSURE

## B.14 BALCONIES

### ISSUE

The stepped back area of the upper three floors of the building massing faces either the mountain view or the lake view. Balconies within that step back would take advantage of the views and animate the character of the facade on Sheridan.

### DESIGN STANDARD

- Balconies may project from the face of the inset portion of the building described above but may not project beyond the face of the primary six story massing of the building.
- The proportion of width of balcony within the recessed area is a maximum of  $2/3$  of the width of the recessed area.

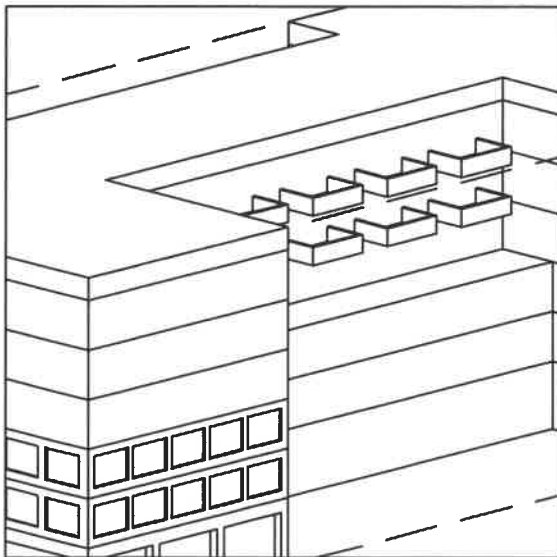

## B.15 HEIGHT AND MASSING ALTERNATIVES

### ISSUE

Edgewater intends to avoid buildings with a monolithic character. A portion of building frontage is to be articulated to step back from the property line. This reduces the mass of the structure while permitting development of six story buildings with continuous, practical floor plates.

### DESIGN STANDARD

- Other portions of buildings above the third floor may also be six stories tall in addition to the six story massing allowed for one third of the site frontage.
- The additional six story massing is allowed only if it is set back fifteen feet from the face of the three story massing of the lower floors below the stepback area.

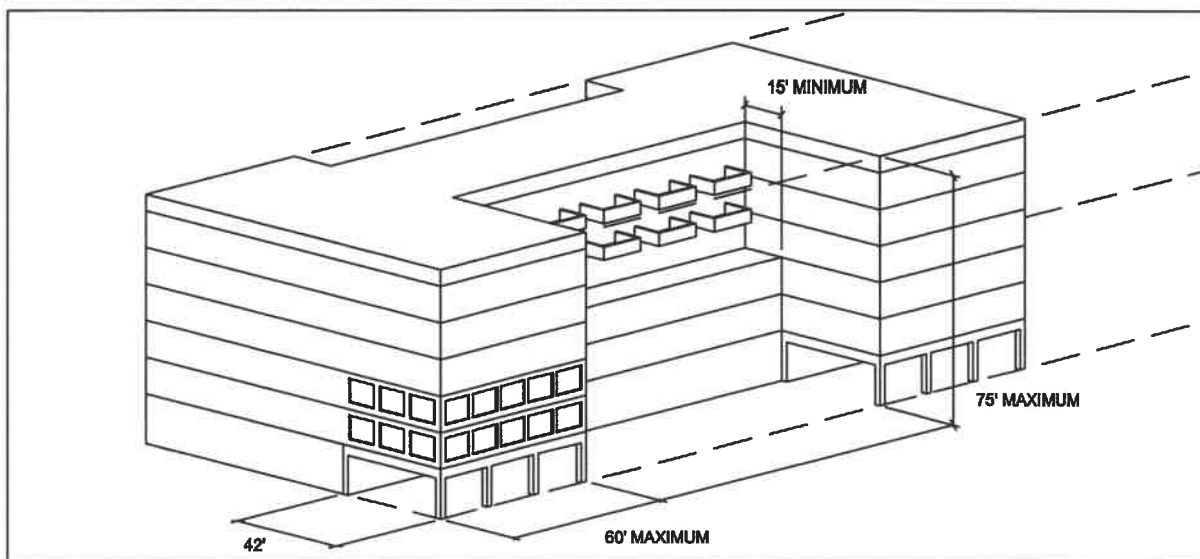
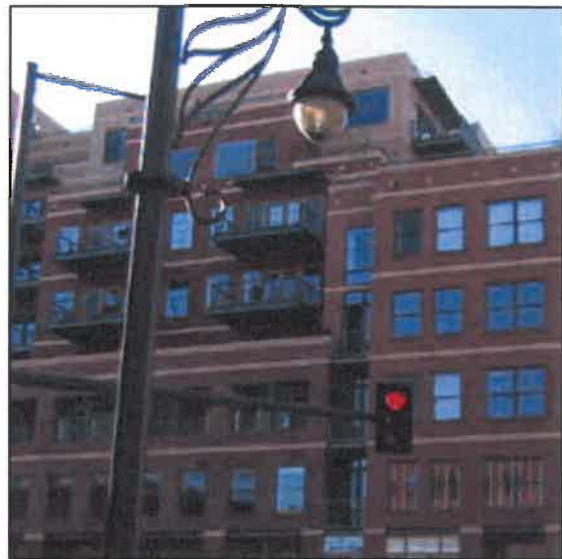



## B.16 CORNER GLAZING

### ISSUE

Street corners are prominent locations for commercial buildings. These corners present ideal opportunities to open up the architectural expression of the new commercial structures and to make them inviting to the passerby.

### DESIGN STANDARD

- The proportion of window to wall at the portion of a building located at a street corner should be increased to include 70% glass at the first three floors rather than just at the street level.
- This fenestration must extend a minimum of 30 feet along both sides of the building located at the corner.

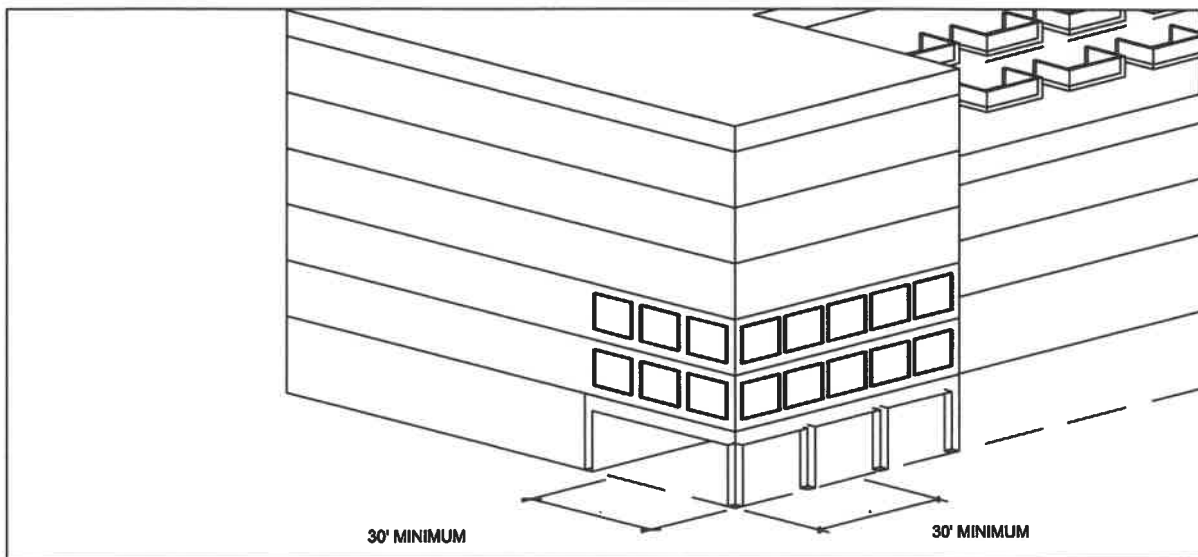

## B.17 ARCADES

### ISSUE

A commercial building with 100' or more of frontage may generate significant pedestrian activity on the relatively narrow sidewalk available on Sheridan Boulevard. A covered arcade makes the street more hospitable and accomodates more pedestrians.

### DESIGN STANDARD

- Arcades must be located at the base of any building with more than one hundred feet of Sheridan Boulevard frontage and built to the property line.
- The minimum clear width of any arcade must be five feet.
- The minimum clear height must be twelve feet.

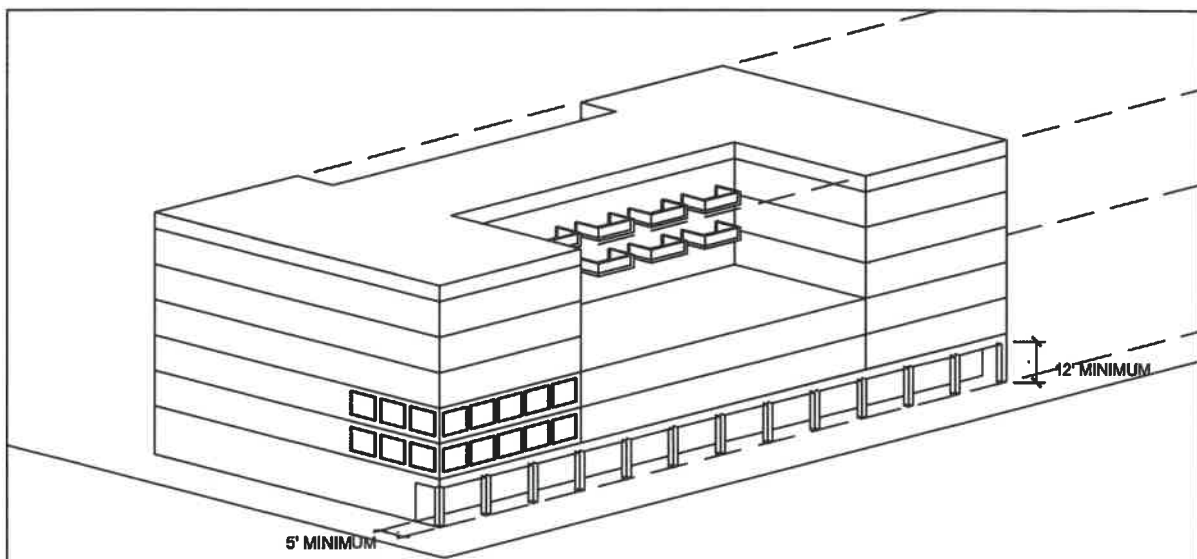

## C.1 HEIGHT AND MASSING

### ISSUE

The surrounding uses are primarily residential and the buildings are low rise. New development should not overwhelm the scale and low density residential character of the adjacent neighborhood.

### DESIGN STANDARD

- Provide structures limited in height to 45 feet to top of roof structure and three stories maximum.
- Encourage mixed use buildings facing 20th Avenue including retail on the ground floor and commercial uses on upper floors.





## C.2 SETBACKS AND BUILD TO LINES

### ISSUE

The pedestrian environment of 20th Avenue is not well defined nor hospitable. Most uses are set back far from the sidewalk. New development should enliven the street and enhance the connection to the park.

### DESIGN STANDARD

- Set commercial structures tight to the property line to create a continuous streetscape to pedestrians and make good use of commercial property.
- New building frontage should be set to the build-to line for 80% of the lot frontage on 20th Avenue.



### C.3 STOREFRONT DESIGN

#### ISSUE

Existing commercial developments either turns its back on 20th Avenue or is automobile oriented. New storefronts should be transparent and inviting to pedestrians.

#### DESIGN STANDARD

- Provide 70% transparent glass storefronts at the ground floor elevation of all buildings facing 20th Avenue.
- Provide doors facing 20th Avenue. Doors must have 50% glass fronting the street. New commercial structures facing 20th Avenue must also have a secondary public entry facing the new parking to the north.



## C.4.a STOREFRONT SIGN DESIGN

### ISSUE

Wall signs are not easily visible from the sidewalk. Artfully done projecting signs add visual interest and human scale to storefronts.

### DESIGN STANDARD

- Provide projecting signs for each commercial and retail tenant fronting on 20th Avenue.
- Provide storefront signs that are projecting signs designed to fit within a 4 foot cube and that incorporate a sculptural element indicating the type of shop or business.
- Encourage signs that which incorporate relatively small type for words.
- Encourage high quality materials, design and craftsmanship in the production of signs.
- Discourage the use of plastics and other low quality materials in the fabrication of signs.
- Limit the amount of glare and spilled light from signs and canopies.
- Encourage careful, high quality lighting of signs. The use of fluorescent lighting and canopies on new signs is not allowed.

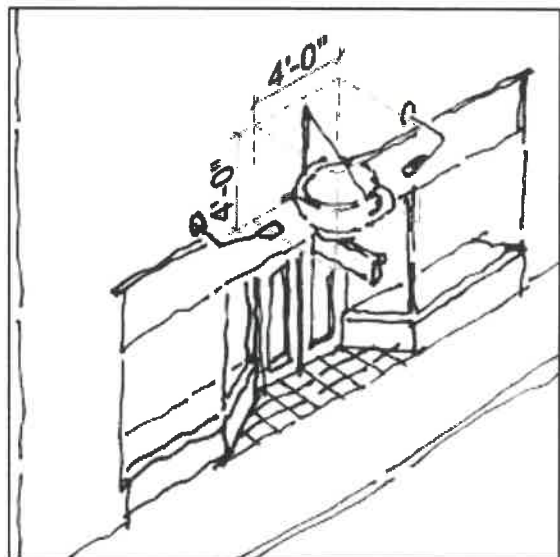
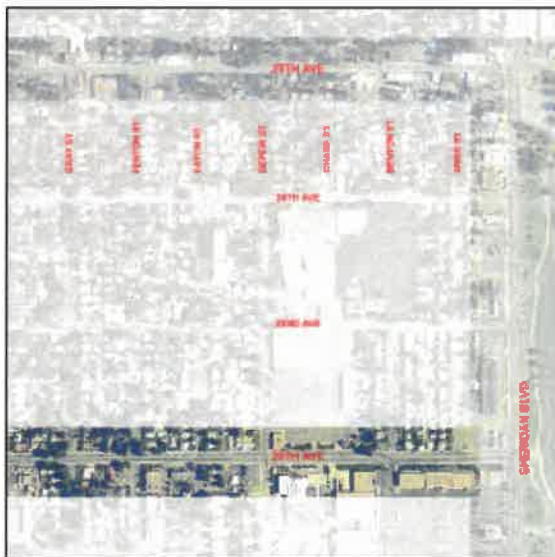



## C.4.b GROUND SIGN DESIGN GUIDELINES

### ISSUE

Large signs of varying height create visual chaos and confusion.

### DESIGN STANDARD

- Provide ground signs for each building or primary tenant in developments bordering 20th Avenue.
- Guide the design of ground signs to be prominent but low in height similar to the Marketplace.
- Discourage the use of visibly thin plastic elements, large plastic surfaces and internally lighted box signs.
- Require the use of high quality materials including metal, stone, glass and neon.

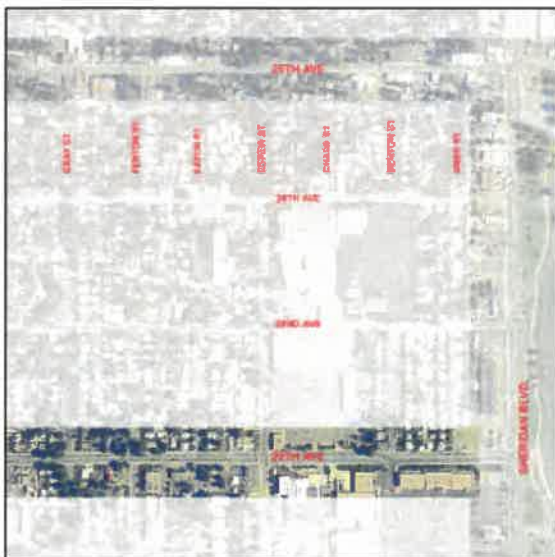
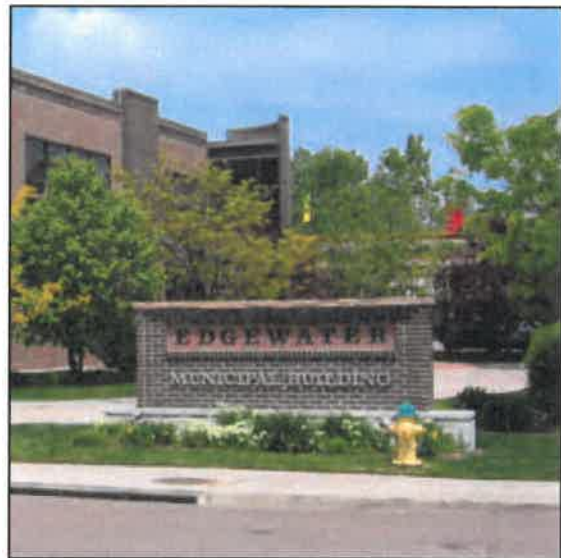

## C.5 EXTERIOR BUILDING MATERIALS

### ISSUE

Controlling the quality of materials creates a level playing field for developers and conveys a message of concern for design and development quality in the community. High quality materials are more durable and better looking than downgraded materials.

### DESIGN STANDARD

- The use of metal clad windows and doors, non-reflective glazing, stone masonry, brick masonry, ceramic tile and architectural grade cast concrete is required in all new construction and exterior renovation.

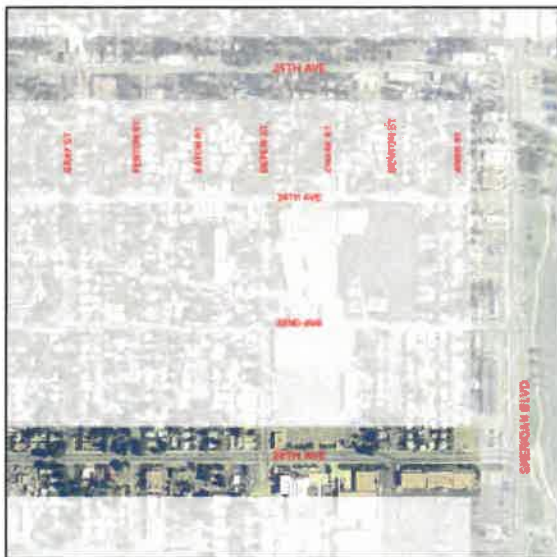

## C.6 INTERMEDIATE AND TOP FLOOR DESIGN GUIDELINES

### ISSUE

Buildings which turn their back on the street or which fail to open to the street take away street life. This downgrades the pedestrian environment and detracts from the inviting commercial character of the street.

### DESIGN STANDARD

Provide large operable windows designed to face the street on all upper levels. Encourage the design of projecting bay rooms, bay windows, planter boxes and balconies facing 20th Avenue. Encourage the design of balcony railings that conceal clutter stored on balconies. Encourage the design of buildings to take advantage of views from upper floors by incorporating balconies and roof decks. Provide decks and balconies designed to be visible from the street.

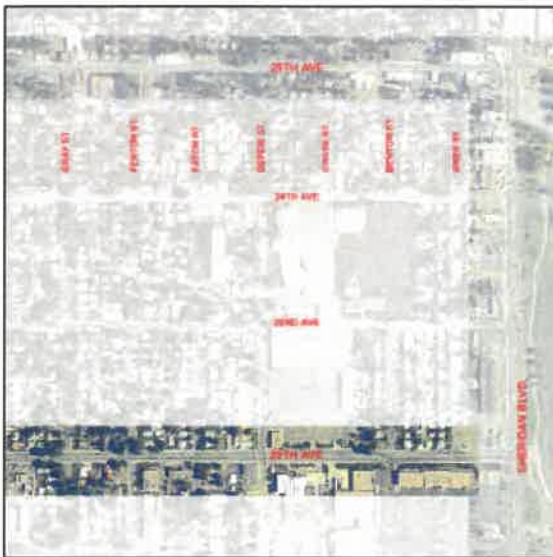



## C.7 WEST END, MIDDLE SECTION, EAST END GUIDELINES

### ISSUE

Along 20th Avenue there are a range of building types and neighborhoods. Design standards should support the positive aspects of each type of neighborhood.

These standards are pertaining specifically to the C-1 zone properties located on 20th Avenue from Sheridan Boulevard to Depew Street.

### DESIGN STANDARD

- Care should be taken in implementing the design standards in reviewing current zoning as it relates to the existing character of 20th Avenue.
- Residential areas which should be preserved should be given special attention however those policies are not a part of these standards.
- The large commercial site at 20th Avenue and Depew is the focus of these design standards. These standards also pertain to redevelopment of other C-1 properties between Sheridan Boulevard and Depew Street.

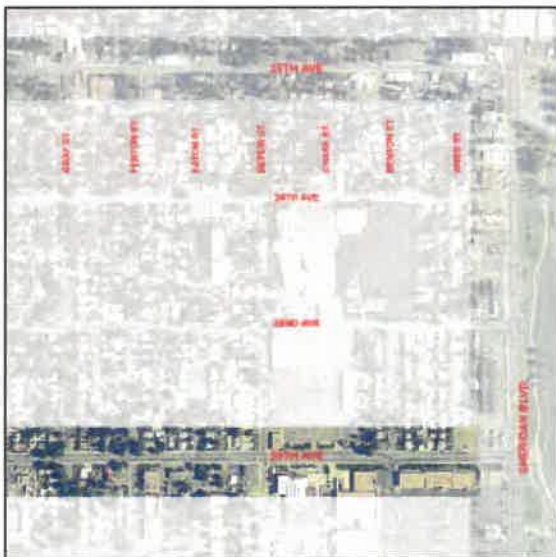

## C.8 STREETSCAPING GUIDELINES

### ISSUE

The quality of the pedestrian environment will benefit from streetscaping. Those improvements if tailored to the needs of commercial users will enhance the viability of the commercial properties along 20th Avenue.

### DESIGN STANDARD

(Re: Marketplace on Sheridan Boulevard)

- Incorporate street trees, tree lawn and detached sidewalks in the design of any new or redeveloped commercial projects.
- Include in the streetscaping the careful use of pedestrian lighting, benches and other street furniture deemed appropriate by the City of Edgewater during the planning and design process.
- All new development on properties adjacent to Sheridan Boulevard must follow the Sheridan Boulevard Design Standards including sites at the corners of 20th Avenue and 25th Avenue. Those design standards extend to the center of the alley between Sheridan and Ames.



## C.9 ARCHITECTURAL DESIGN GUIDELINES

### ISSUE

Good architectural and landscape design will enhance the commercial environment and help attract better development and better commercial uses to the 20th Avenue district.

### DESIGN STANDARD

- Encourage elegant buildings appropriate to an important urban avenue with clean lines, and a predominance of large openings addressing the street.
- Develop more detailed materials guidelines based on integrity of materials and good design. Avoid unfounded references to historical styles or superfluous ornamentation.
- Encourage careful design of landscape materials, exterior lighting and good graphic design.





**CITY OF EDGEWATER URBAN DESIGN STANDARDS  
SHERIDAN BOULEVARD**



**CITY OF EDGEWATER URBAN DESIGN STANDARDS  
25TH AVENUE**





CITY OF EDGEWATER URBAN DESIGN STANDARDS  
25TH AVENUE





**CITY OF EDGEWATER URBAN DESIGN STANDARDS  
SHERIDAN BOULEVARD**



ARCADES MUST BE LOCATED AT THE BASE OF ANY BUILDING MORE THAN ONE HUNDRED FEET WIDE AND SET TIGHT TO THE PROPERTY LINE. THE MINIMUM CLEAR WIDTH OF ANY ARCADE MUST BE FIVE FEET. THE MINIMUM CLEAR HEIGHT MUST BE TWELVE FEET.

B.17

THE PROPORTION OF WINDOW TO WALL AT THE PORTION OF A BUILDING LOCATED AT A STREET CORNER SHOULD BE INCREASED TO INCLUDE 70% GLASS AT THE FIRST THREE FLOORS RATHER THAN JUST AT THE STREET LEVEL.

B.16

B.15 IN ADDITION TO THE SIX STORY MASSING ALLOWED FOR ONE THIRD OF THE SITE FRONTAGE PORTIONS OF BUILDING ABOVE THE THIRD FLOOR MAY ALSO BE SIX STORIES TALL BUT ONLY IF SET BACK FIFTEEN FEET FROM THE FACE OF THE PRIMARY SIX STORY MASSING.

B.14 BALCONIES MAY PROJECT FROM THE FACE OF THE INSET PORTION OF THE BUILDING DESCRIBED ABOVE BUT MAY NOT PROJECT BEYOND THE FACE OF THE PRIMARY SIX STORY MASSING OF THE BUILDING.

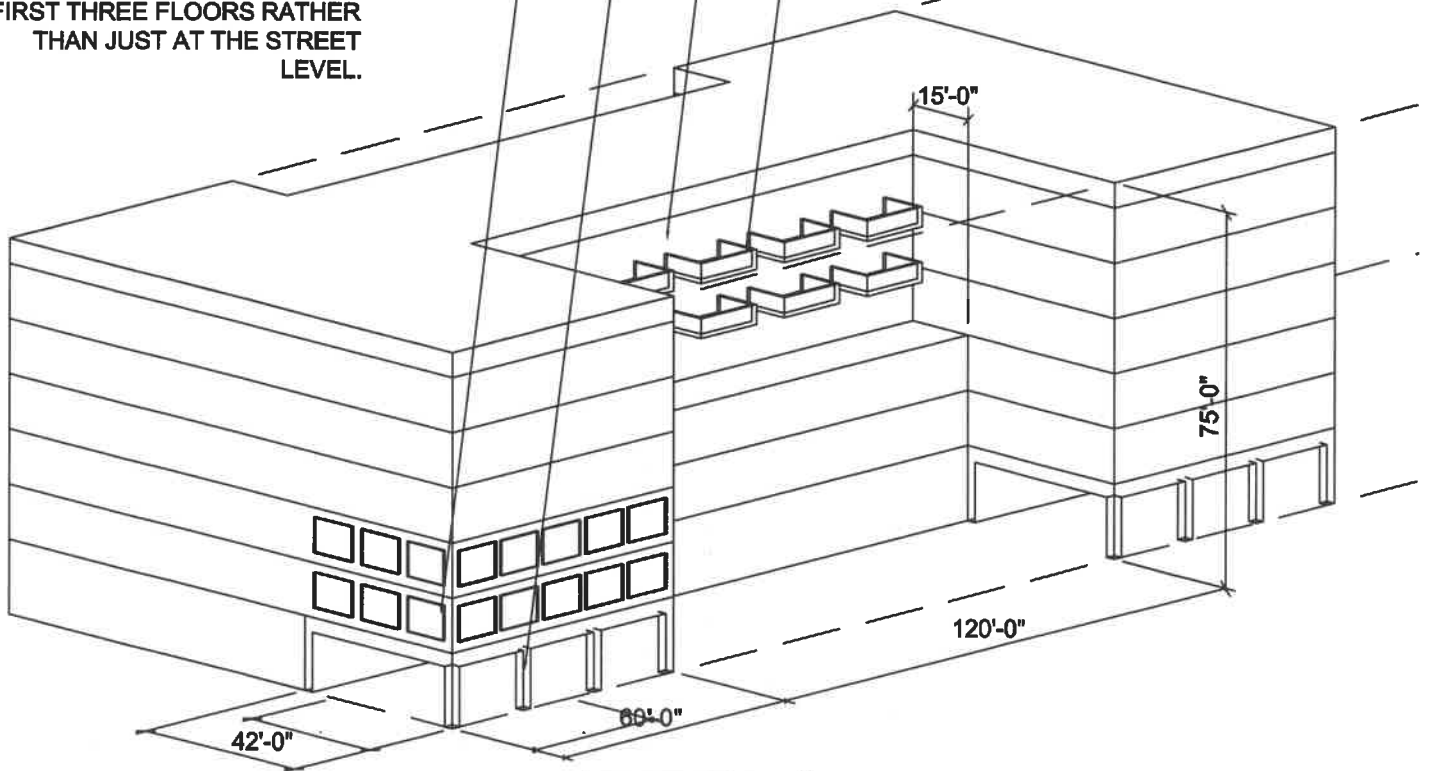

**CITY OF EDGEWATER**

**RESOLUTION NO. 30-04**

**A RESOLUTION APPROVING AND ADOPTING AMENDMENTS TO THE URBAN DESIGN STANDARDS FOR 20<sup>TH</sup> AVENUE, 25<sup>TH</sup> AVENUE AND SHERIDAN BOULEVARD.**

**WHEREAS**, the City Council has adopted design standards to preserve the character of its primary business corridors located on 20<sup>th</sup> Avenue, 25<sup>th</sup> Avenue and Sheridan Boulevard; and

**WHEREAS**, the City Council desires to adopt certain revisions to the Design Standards, proposed by the Planning and Zoning Commission, to clarify various design standards on 20<sup>th</sup> Avenue, 25<sup>th</sup> Avenue and Sheridan Boulevard; and

**WHEREAS**, such revisions to the Design Standards are contained in Exhibit A, a copy of which is attached hereto and incorporated herein by this reference.

**BE IT RESOLVED BY THE CITY COUNCIL OF THE CITY OF EDGEWATER, COLORADO:**

**Section 1.** The City Council of the City of Edgewater hereby approves and adopts the revisions to the City of Edgewater Urban Design Standards as set forth in Exhibit A, attached hereto and incorporated herein by this reference.

**Section 2.** All applicants for subdivision, zoning, rezoning or development of properties located on 20<sup>th</sup> Avenue, 25<sup>th</sup> Avenue and Sheridan Boulevard shall be advised as to the existence of Exhibit A amending the Design Standards, and a copy thereof shall be made available to such applicants.

**Section 3.** If any portion of the Design Standards approved and adopted by this Resolution is held to be invalid for any reason, such decision shall not affect the validity of the remaining portions of such Design Standards. The City Council hereby declares that it would have approved and adopted such Design Standards and each part thereof irrespective of the fact that any one part be declared invalid.

**INTRODUCED, READ, and ADOPTED** this 21st day of October, 2004.

CITY OF EDGEWATER, COLORADO



Bob Prewitt, Mayor

ATTEST:

  
Gayle Martinez, City Clerk

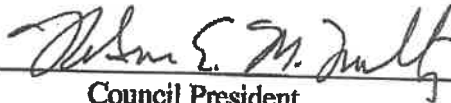
  
Council President

APPROVED AS TO FORM:

  
City Attorney



## EXHIBIT A

### Revisions to City of Edgewater Urban Design Standards (Words to be deleted ~~stricken through~~; words to be added underlined)

#### Sheet Number A.1:

1. Revise the design standards to read as follows; ~~Provide structures limited in height to 45' to top of roof structure and three stories maximum. Eliminate the pressure to develop taller buildings in the 25<sup>th</sup> avenue district.~~ “For any use other than single family residential, provide structures limited in height to 45’ to top of roof structure and three stories maximum. Any single family structure shall be limited in height to 35’ maximum. Maintain a district of walk up scale buildings. Where underlying zoning permits, encourage mixed use buildings including retail, office and residential on separate floors of three story buildings. Provide with services and parking behind and below grade under such buildings.”

#### Sheet Number A.3:

3. Revise the design standards to read as follows; “Provide 70% transparent glass storefronts at the ground floor elevation of all commercial buildings facing 25<sup>th</sup> Avenue. Continue glass to sidestreet elevations on corner lots. Provide doors at commercial spaces with 50% glass fronting the street and recessed to allow door to swing out.” ~~Provide storefronts designed to follow traditional details and proportions as established by the U.S. Department of Interior.~~

#### Sheet Number A.4:

4. Revise the first design standard to read; “Provide storefront signs that are either projecting signs or wall signs flush with the building and designed to fit within a 4 foot cube and that incorporateing a sculptural element indicating the type of shop or business and with relatively small type used for words. Projecting signs shall be no closer than two feet to the edge of the curb and shall be no higher than the parapet of the building.”

#### Sheet Number A.5:

5. Revise the design standards to read as follows; “Provide ~~high quality brick~~ masonry construction for all exterior wall surfaces at all new commercial building fronts on 25<sup>th</sup> Avenue and at all walls facing side streets ~~at~~ and corners. Back walls and alley walls may be stucco. Brick materials are to be similar to the existing buildings in size, module and in surface texture. Downgraded materials such as synthetic stucco, wood siding, metal siding, vinyl siding, cement siding, concrete masonry, flat-face cinder block and other substitutions are not disallowed. Split-face concrete block is a permitted material.”

#### Sheet Number B.3:

7. Revise the third design standard to read as follows; Adapt “Design all new

landscape plans to compliment future redevelopment of the deceleration lane as tree, lawn and sidewalk space." ~~appropriate to larger high quality high density development.~~

**Sheet Number B.4:**

8. Revise the second design standard to read, "With each development application for parcels fronting Sheridan Boulevard, ~~examine and evaluate the possibility of reclaiming the deceleration lane~~ landscape plan for compatibility with future use of the deceleration lane as space for streetscaping."

**Sheet Number C.5:**

9. Revise the design standard to read, "The use of metal clad windows and doors, non-reflective glazing, stone masonry, brick masonry including split-faced block, ceramic tile and architectural grade cast concrete is required in all new construction and exterior renovation."

**Sheet Number C.7:**

10. Delete the design standard in entirety as shown here.  
~~Care should be taken in implementing the design standards in reviewing current zoning as it relates to the existing character of 20<sup>th</sup> Avenue. Residential areas which should be preserved should be given special attention however these policies are not a part of these standards. The large commercial site at 20<sup>th</sup> Avenue and Depew is the focus of these design standards. These standards also pertain to redevelopment of other C-1 properties between Sheridan Boulevard and Depew Street.~~

**Sheet Number C.9:**

11. Revise the first design standard to read as follows; "Encourage ~~elegant buildings appropriate to an important urban avenue with clean lines and~~ a predominance of large openings addressing the street."

**Addition of New Design Standards titled Rooftop Mechanical Equipment:**

12. Amend the 25<sup>th</sup> Avenue design standards by the addition of a Standard A.12, which shall have the following sections and read as follows: "ISSUE: Rooftop mechanical equipment can be unsightly when viewed from adjacent properties or rights-of-way. Such equipment added to an existing building can seriously diminish the traditional character of the building. DESIGN STANDARD: Require screening of any newly installed rooftop mechanical equipment visible from adjacent properties and rights-of way. Screening must be high-quality material and must compliment the building color."

13. Amend the Sheridan Boulevard design standards by the addition of a Standard B.18, which shall have the following sections and read as follows: "ISSUE: Rooftop mechanical equipment can be unsightly when viewed from adjacent properties or rights-of-way. Such equipment added to an existing building can seriously diminish the traditional character of the

building. DESIGN STANDARD: Require screening of any newly installed rooftop mechanical equipment visible from adjacent properties and rights-of way. Screening must be high-quality material and must compliment the building color."

14. Amend the 20<sup>th</sup> Avenue design standards by the addition of a Standard C.10, which shall have the following sections and read as follows: "ISSUE: Rooftop mechanical equipment can be unsightly when viewed from adjacent properties or rights-of-way. Such equipment added to an existing building can seriously diminish the traditional character of the building. DESIGN STANDARD: Require screening of any newly installed rooftop mechanical equipment visible from adjacent properties and rights-of way. Screening must be high-quality material and must compliment the building color."